

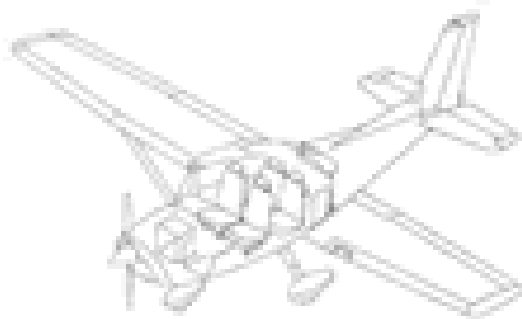

# ***KEMPSEY FLYING CLUB***

## ***NEWSLETTER***



Flying Club Office and Clubrooms:

Phone: 02 6562 6202

Fax: 02 6562 6202

**Issue 27    Jan, Feb, Mar, Apr, May, Jun 2008**

## ATKINS & HOLDT PTY LTD



*Your local  
Bosch Bloke*

All Auto-Electrical Repairs  
Fuel Injection  
Engine Management  
Engine Immobilisers  
Fitting Kill Switches  
Air Conditioning

After Hours Service  
**04 2865 6237**

**Ph: 02 6562 4691**  
84 Belgrave Street Kempsey

## Summerville

### Daley P/L

- ◆ Certified Accountants
- ◆ Financial Planners
- ◆ Taxation Consultants
- ◆ Business Consultants

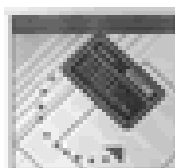

32 Clyde Street  
Kempsey

**Phone: 6562 7533**

### Office Bearers 2007-2008:

President:	Milton Riggs	Ph: 6562 5725
Secretary:	Tom Dick	Ph: 6562 4365
Treasurer:	Lyll Notley	Ph: 6562 4858
Vice President:	Paul Stubbs	Ph: 6566 9224
Vice President:	Graeme Smith	Ph: 6566 9231
Club Captain:	Warren McCully	Ph: 6567 1360
Committee:	Peter Howard	Ph:
	Neville Gibson	Ph: 6562 8390
	Hilton McLeod	Ph: 6562 6556

### SUBS WERE DUE ON THE 1<sup>st</sup> April 2008:

**\$33.00 Flying inc GST or \$5.50 Social inc GST**

**\$11.00 Joining Fee (Flying Members) inc GST**

## President's Report - June 2008

The Annual General Meeting of your club was held on the 19<sup>th</sup> May 2008 with minor changes to your board. Graeme Smith did not stand this year as president because of busy commitments this year. There being no nominations for the position of President, nominations were called from the floor. As there was only one nomination being yours truly, I accepted the position for the next twelve months. The other change on the committee is Peter Howard replaces Peter Ackerly.

Graeme's commitment for the year is a four wheel drive trip across the deserts of this vast country. Naturally he is not doing this by himself there are three other diehards going also. The main stay for this journey will be Hiltie McLeod (Chief Engineer and Home Brew Distributor). Have a safe and enjoyable time fellas. Their story will appear in the next edition of your newsletter.

This now has a website, thanks to Darren Gibson, who has allowed us to piggyback behind his website. Log on to the website [Kempseyflyingclub.com.au](http://Kempseyflyingclub.com.au)

VH-TDK has just had a Periodic/100hr inspection. Seat belt webbing has been replaced, the exhaust muffler overhauled, landing and taxi light covers have also been overhauled.

I remind pilots that when you hire VH-TDK ensure that you check the maintenance release before flying. There are a number of A/D's (Airworthiness Directives) showing on the maintenance release to be carried out at various times. Should you ignore an A/D and fly the aircraft (VH-TDK) with an overdue A/D and there is an incident the insurance could be made null and void. **Check the maintenance release at all times.** The times for the A/D's is Tacho time not VDO time.

With the escalating price of avgas it has become necessary to increase the hire time for VH-TDK from \$138 per VDO hour to \$144 per VDO hour (not tacho time). It was inevitable that the price rise had to occur and no doubt it will rise again, in the future, should the fuel price go higher.

Some of you may not be aware that Kempsey Flying Club Ltd became a company limited by guarantee and not having a share capital on 25<sup>th</sup> September 1961, meaning your club will become 47 years old as a limited company on 25<sup>th</sup> September 2008. Maybe we should be looking forward to a 50<sup>th</sup> anniversary celebration in the year 2011.

That's all from me this time, enjoy your flying and social activities, Bar-b-q every 1<sup>st</sup> Sunday of the month and flying comp every 3<sup>rd</sup> Sunday.

If you have a minor problem concerning Kempsey Flying Club Ltd you can contact me personally on 6562 5725, however with a serious problem please put it in writing and the committee will look into it.

Milton Riggs

President



## Secretary's Report:

- **Jan** - 8 committee members attended the January meeting.
- ❖ Three members from the Coffs Harbour club dropped in to tell us about their fly-in which will be in October
- **Feb** - 6 committee members attended the February meeting.
- ❖ Kempsey Shire Council sent a letter regarding a new focus group to be set up to advise on the future development of the airport. Milton Riggs and Tom Dick were nominated to represent the club on the committee. *(Both were subsequently knocked back by the Council).*
- **Mar** - 8 committee members attended the March meeting.
- ❖ Kempsey Shire Council sent a letter regarding a new focus group to be set up to advise on the future development of the airport. Milton Riggs and Tom Dick were nominated to represent the club on the committee. *(Both were subsequently knocked back by the Council).*
- **Apr** - 7 committee members attended the April meeting.
- ❖ Kempsey Shire Council advised holes in landing area would be rectified.
- **May** - Annual General and Committee Meeting-17 members attended.
- ❖ Financial statements were presented and adopted. The new committee was elected with only three changes - Peter Ackerley retired and was replaced by Peter Howard - plus Graeme Smith retired as president and was replaced by Milton Riggs. Milton Riggs retired as Vice President and was replaced by Graeme Smith. (See page one for list).
- **Jun** - 7 committee members attended the June meeting.
- ❖ The Committee advises there is a Web Site up for the club and a letter of thanks has been sent to Darren Gibson at Macleay Aircraft Maintenance for facilitating it via his web site.
- ❖

**Tom Dick**  
**Secretary**

Kempsey Flying Club has for sale:

<b>Club Badges</b>		<b>\$5.00 ea</b>
<b>Cloth Badges</b>		<b>\$7.50 ea</b>
Coffee Mugs	\$5.00 ea or	\$18.00 set of 4
New Kempsey Flying Club caps		\$14.00 ea

(They are navy blue, with 'Kempsey Flying Club' embossed in pale blue. Get in quick!)

## MESSAGE FROM THE EDITOR:

The communications of your club revolve around your newsletter!! It is over a year since the last newsletter mainly due to a lack of news.

Got any thoughts about a social or flying function which you (particularly new members) would like to attend?

Maybe we could combine our monthly family Bar-b-q with a "meet the new members" night and have a look at some flying videos or play some old 78 records - anyone got any of these things?

Maybe we could organize a flying/driving weekend to Temora?

These are just my thoughts but please advise one of the committee or write your support for these ideas or your other suggestions on the blackboard in the club.

A web site [kempseyflyingclub.com.au](http://kempseyflyingclub.com.au) has been launched thanks to Macleay Aircraft Maintenance for allowing it to sit at the back of their site and to Announce IT for the production of the site. All future newsletters will be posted on the web site.

To save the club postage and photocopying all those **members who have an email address are requested to send it to [bevandbev@dodo.com.au](mailto:bevandbev@dodo.com.au)** and your newsletter will be emailed in future.

Don't forget!! Items of interest for future issues, from members, make it more interesting. Any further history and photographs for the web site would also be appreciated. Contact Bev & Neville Gibson with your stories etc. at 6562 8390 or [bevandnev@dodo.com.au](mailto:bevandnev@dodo.com.au)

Enjoy your flying,

Bev



## HOURGLASS JEWELLERS

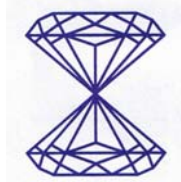

Centrepoint Arcade  
Kempsey

Phone: 02 6562 5759  
Fax: 02 6562 5587

*Your locally owned  
and operated Jewelry  
store for 30 years*

Paul Stubbs Law Office



**-SOLICITORS-**

**PAUL STUBBS  
LEAH MORRISON**

- ◆ Conveyancing & Leases
- ◆ Third Party, Personal Injury & Compensation Claims
- ◆ Wills & Estates
- ◆ Family Law
- ◆ Court Proceedings

44 Belgrave Street  
Kempsey  
Phone: 02 6562 1234  
Also 12 Landsborough Street  
South West Rocks  
Phone: 02 6566 5055

## Calendar of Events - August 2008 to October 2008

		August		September		October		November
M			1					
T			2					
W			3		1			
T			4		2			
F	1		5		3			
S	2		6		4		1	
<b>S</b>	3	<b>Family BBQ – Working Bee</b> Duty Pilot Peter Howard	7	<b>Family BBQ – Working Bee</b> Duty Pilot Neville Gibson	5	<b>Family BBQ – Working Bee</b> Duty Pilot Peter Howard	2	<b>Family BBQ – Working Bee</b> Duty Pilot Warren McCully
M	4		8		6		3	
T	5		9		7		4	
W	6		10		8		5	
T6	7		11		9		6	
F	8		12		10		7	
S	9		13		11		8	
<b>S</b>	10	Duty Pilot Hilton McLeod	14	Duty Pilot Tom Dick	12	Duty Pilot Hilton McLeod	9	Duty Pilot Neville Gibson
M	11		15	<b>Committee Meeting 8pm</b>	13		10	
T	12		16		14		11	
W	13		17		15		12	
T	14		18		16		13	
F	15		19		17		14	
S	16		20		18		15	
<b>S</b>	17	<b>Flying Comp</b> Duty Pilot Milton Riggs	21	<b>Flying Comp 3pm</b> Duty Pilot Lyall Notley	19	<b>Flying Comp 3pm</b> Duty Pilot Milton Riggs	16	<b>Flying Comp 3pm</b> Duty Pilot Tom Dick
M	18	<b>Committee Meeting 8pm</b>	22		20	<b>Committee Meeting 8pm</b>	17	<b>Committee Meeting 8pm</b>
T	19		23		21		18	
W	20		24		22		19	
T	21		25		23		20	
F	22		26		24		21	
S	23		27		25		22	
<b>S</b>	24	Duty Pilot Graeme Smith	28	Duty Pilot Paul Stubbs	26	Duty Pilot Graeme Smith	23	Duty Pilot Lyall Notley
M	25		29		27		24	
T	26		30		28		25	
W	27				29		26	
T	28				30		27	
F	29				31		28	
S	30						29	
<b>S</b>	31	Duty Pilot Warren McCully					30	Duty Pilot Paul Stubbs
M								
T								

## TDK Report:



During the last six months – January to June TDK has flown a total of 54 hours – more are needed!!

In this time the following maintenance has been carried out:

- ◆ Nose leg has been recharged.
- ◆ The vac pump has been replaced.
- ◆ The periodic inspection has been carried out.
- ◆ Muffler has been rebuilt.
- ◆ Landing light housing repaired.
- ◆ All Airworthiness Directives have complied.

Flying rates are \$144.00 per hour for club members and \$177.00 for others. Don't forget your pre-flight checks, especially the maintenance release, current medical and BFR are required with a minimum 30 minutes per booking.

Pilots are reminded that when you hire VH-TDK ensure you check the maintenance release before flying. There are a number of A/D's (Airworthiness Directives) showing on the maintenance release to be carried out at various times. Should you ignore an A/D and fly the aircraft (VH-TDK) with an overdue A/D and there is an incident the insurance could be made null and void. **Check the maintenance release at all times.** The times for the A/D's is Tacho time not VDO time.

### **MORE IMPORTANT NOTICES for TDK:**

Pilots do not prime TDK motor using the instrument light knob – use the PRIMER!!! This has happened three times – if you do damage it please report it.

Pilots are reminded it is now LAW that whilst TDK is parked outside the hangar the **THROTTLE LOCK** must be in place.

*The lock is red and can be found in the pocket behind the pilot's seat. The key is on the ring with the aircraft keys.*

***Aircraft Paperwork to be completed:***

<u>Maintenance Release</u>	Records Tacho time and maintenance due on aircraft
<u>Aircraft</u>	Blue Book Records VDO time
<u>Clubhouse</u>	Flight Sheet records VDO time Post flight minor maintenance report.

***Medicals & Flight Reviews:***

Our secretary Tom Dick is currently checking all flying members, photocopying and recording all Pilot Medicals and Biennial Flight Reviews. Don't forget to check that your BFR and medical is up to date then contact Tom with the information.

This is essential to enable you to fly the Club aircraft, TDK. Many members are not complying with this important procedure.

**TDK Hire:**

<b>Minimum Hire</b>	<b>30 mins. VDO</b>
<b>Members</b>	<b>\$144.00 per hour inc GST</b>
<b>Non Members</b>	<b>\$177.00 per hour inc GST</b>

**Anyone interested in hiring the Aircraft should contact the Club's Secretary, Tom Dick - Tel: 6562 4365.**

--ooOoo--

**CHANGES TO TDK HIRE TERMS:**

12. "The hirer will be responsible for the return of the aircraft to Kempsey in all circumstances where Kempsey Flying Club Ltd will not otherwise be re-imbursed for the cost of retrieval of the aircraft.
13. The hirer will utilize the aircraft for a minimum average of two hours per day for hirings in excess of three days."

## Club Report:

Comps have continued with good attendance and fierce competition. Don't forget the sausage sizzle which follows the comp!!

### KEMPSEY FLYING CLUB LTD 2008 COMPETITION

#### MONTHLY POINT SCORE

	Dec	Jan	Feb	Mar	Apr	May	Jne	Jly	Aug	Sep	Oct	Nov	Tot
T Dick	5	20	5	10	*	5	5						
G Smith	15	15		20	A	15	5						
HMcLeod	5	5	5	5	R	10	5						
PAckerley	5				M		5						
P Stubbs		10		5	I								
C Mahoney				5	D								
B Bishton		5		15	A	5	5						
W McCully	10	5	5	5	L	5	5						
L O'Dell	20	5	5	5	E	20	5						
TBonhomm		5		5	*		5						

## HOW DOES A PILOT KNOW THE AIRCRAFT IS FIT TO FLY

(From a Pilot's Guide to Aircraft Maintenance June 1994)

While the overall responsibility for ensuring required maintenance is carried out lies with the Certificate of Registration holder, you, as a pilot, must ensure certain conditions are met before flight.

The key to an aircraft's continued airworthiness is the Maintenance Release, a document which actually forms part of the permanent maintenance records for an aircraft.

**1. To determine whether your aircraft is fit to fly, first ensure that:**

- ◆ The Maintenance Release will remain valid for the period of the intended flight.
- ◆ You are satisfied that any defects or endorsements on the Maintenance Release are acceptable for the duration of the intended flight.
- ◆ You have carried out a thorough Daily or Preflight inspection.
- ◆ Any defects or damage found during the Daily or Preflight inspection are entered on the maintenance release and/or, as applicable, brought to the attention of the appropriate person responsible for the maintenance of the aircraft.

**2. The Maintenance Release also provides information you need in order to judge the serviceability of your aircraft and to decide if any defect or maintenance requirements listed will affect the safety of your operation.**

**"Laughter on the Wing"**

## DUTY PILOT ROSTER 2007-2008

June	1	Peter Howard	Dec	7	Peter Howard
	8	Hilton McLeod		14	Hilton McLeod
	15	Milton Riggs		21	Milton Riggs
	22	Graeme Smith		28	Graeme Smith
	29	Warren McCully	Jan	4	Warren McCully
July	6	Neville Gibson		11	Neville Gibson
	13	Tom Dick		18	Tom Dick
	20	Lyall Notley		25	Lyall Notley
	27	Paul Stubbs	Feb	1	Paul Stubbs
Aug	3	Peter Howard		8	Peter Howard
	10	Hilton McLeod		15	Hilton McLeod
	17	Milton Riggs		22	Milton Riggs
	24	Graeme Smith	Mar	1	Graeme Smith
	31	Warren McCully		8	Warren McCully
Sept	7	Neville Gibson		15	Neville Gibson
	14	Tom Dick		22	Tom Dick
	21	Lyall Notley		29	Lyall Notley
	28	Paul Stubbs	Apr	5	Paul Stubbs
Oct	5	Peter Howard		12	Peter Howard
	12	Hilton McLeod		19	Hilton McLeod
	19	Milton Riggs		26	Milton Riggs
	26	Graeme Smith	May	3	Graeme Smith
Nov	2	Warren McCully		10	Warren McCully
	9	Neville Gibson		17	Neville Gibson
	16	Tom Dick		24	Tom Dick
	23	Lyall Notley		31	Lyall Notley
	30	Paul Stubbs			

The  
**Bowen Technique**



The Bowen Technique is a revolutionary healing modality which resets and balances the body's energy, allowing it to heal itself with minimum intervention.

Bowen successfully addresses many conditions from muscular skeletal complaints to conditions such as chronic fatigue. The list is huge so for more info please refer to [www.bowtech.com](http://www.bowtech.com) or call

**ROSLYN BRYANS**

Bowen Therapist

Psychotherapist/Counsellor

**65671360**

✪ *for all things aircraft* ➔

**Macleay Aircraft  
Maintenance**



**Hangar 5 Kempsey Airport**

Phone: 02 6563 1406

A/Hrs: 04 1744 6521

- ◆ **Regular Maintenance**
  - ◆ **C of A Inspections**
  - ◆ **Rebuilds including interiors**
  - ◆ **Aircraft Painting**
  - ◆ **Corrosion Treatment**
  - ◆ **Pilot Supplies**
  - ◆ **Free Coffee**
- ✪ **Aircraft supplies from all over the world are at our fingertips**

**WE WELCOME THE FOLLOWING NEW MEMBERS:**

Steve Crossingham - Kempsey

Voula Crossingham - Kempsey

Barry Price - Coffs Harbour

Edward Fullerton - Macksville

Paul Foster - Eungai

Dorothy Scott - Wauchope